

INFLUENCE OF CORPORATE IMAGE AND RELATIONSHIP QUALITY ON CUSTOMER TRUST AND CUSTOMER LOYALTY ON THE PT GARUDA INDONESIA IN SURABAYA

Jan Wellyan

Widya Mandala Chatholic University Surabaya, Indonesia

E-mail: janwellyan@gmail.com

ABSTRACT

In essence, this study tested the theory of loyalty Morgan & Hunt, The populations are all domestic passengers PT. Garuda Indonesia in Surabaya, used a sample $n = 150$, the sampling technique used is purposive sampling. The research is exploratory research with SEM as analysis tools. Hypothesis 1-5, accepted. which means that every increase in Corporate image will increase customer trust, every increase in relationship quality will increase customer trust, every increase in corporate image will raise Customer loyalty, every increase in relationship quality will raise Customer loyalty, and every increase in customer trust will increase customer loyalty. The path coefficient from customer trust provides the largest indirect effect on relationship quality (Internal Information) on customer loyalty. this study indicate that the corporate image and relationship quality has direct impact on customer loyalty or through customer trust, and customer trust does have a significant direct effect on customer loyalty.

Keywords: *Corporate Image, Relationship Quality, Customer Trust, Loyalty.*

1. INTRODUCTION

Corporate image and relationship quality are the foundation in building customer trust. The impact of corporate image and relationship quality on customer trust has been studied intensively but the results are still debatable. Ellinger et al. (1999) found that formal meetings with the customers (relationship) and then let the customers express their opinion (image) make customers get more satisfied and finally get more loyal. Lin and Lu (2010) found that positive corporate image has significant effect on customer trust. Besides, they also found that product image has the most significant effect on customer trust, followed by functional image and institutional image. But other researchers also found that sales person behavior has significant effect on customer trust (Pappas & Flaherty, 2008; Swan et al., 1999). This finding is supported by Ruyter *et al.* (2001) who found that attributes bid and supporting from the staff can lead to the customer trust. Miyamoto and Rexha (2004) also found that satisfying relationship could create customer trustworthy. Nguyen dan Leblanc (2001) found that corporate image, such as name, building, product or service quality, could strengthen customers opinion on corporate image.

Corporate image could help customers to get better understanding of products provided by a company and could reduce their hesitation in making buying decisions (Robertson dan Gatignon, 1986). Therefore it is very important to build a positive corporate image in customers mind (Chattananon et al., 2008) because it could increase customers' loyalty and in turn could increase company's sales and profits (Adkins, 2004). Based on those debatable research findings, this paper aims to develop and test two new models of the relationship among corporate image, relationship quality, customer trust, and customer loyalty. The first is model that tries to build a customer trust through corporate image and relationship quality. The second is model that tries to test the effect of customer trust on customer loyalty.

2. LITERATURE REVIEW

2.1 Corporate Image

According to Kandampully dan Hu (2007) corporate image consists of two components, functional and emotional. Functional is corporate real characteristic that can be measured and evaluated easily. Emotional is sense of belonging, attitude and trustworthy to an

organization. All these attributes have significant contribution to build corporate image. Corporate image can be defined as “the overall impression” embedded in customers mind as a result of the accumulation of feelings, ideas, attitudes and experiences with the organization that are kept in customer memory, and the meaning can be changed to be positive or negative when taken to construct a figure or memory when the name of an organization is called or brought to peoples mind (Kazoleas *et al.*, 2001; Hatch *et al.*, 2003; Bravo *et al.*, 2009). Customers even can act as a limit spanning that can relate a commercial organization from insider to outsider information and spread over the information to all, and this also knows as “*discretionary behavior*” (Chung dan Schneider, 2002; Slatten, 2008).

Therefore corporate image is a result of communication process which a company creates and spreads over any kind of messages such as vision, mission, objectives, strategies and identity that reflected the corporate core values that it share with (Bravo *et al.*, 2009). In some cases, corporate image could be a highly valuable asset that a company should manage it properly (Abratt & Mofokeng, 2001). Good image can increases company’s sales, and customer satisfaction and loyalty, and can attract new investors and employees in the future. Corporate image could also weaken the negative effect of the competitor and enable an organization to attain higher level of achievement, not just a profit (Kim *et al.*, 2011).

2.2 Relationship Quality

Roos (2002) defined relationship quality as a catalytic or mixed understanding that make customers to be sensitive for switching. Relationship quality is viewed as a main indicator to measure the strength of relationship (Garbarino dan Johnson, 1999). Some empirical studies revealed that relationship quality a construct that consist of at least two dimensions: trust and satisfaction. When customers involve in a good relationship with a service company then they will be satisfied and depend on the service company. Many other researchers also find that commitment is the most important thing in building a good relationship between company and it’s customers (Wulf *et al.*, 2001; Hennig-Thurau *et al.*, 2002).

Relationship quality is referred to all strengths of the relationship between two parties (Palmatier *et al.*, 2006). Relationship quality has been emerged as a new paradigm that show to some extent a customer trust the service provider’s performance in the future because of its persistent satisfying past performance. Relationship quality usually conceptualized as a composite construct or a multidimensional aspect of differences but correlated each other (Lages *et al.*, 2005; Palmatier *et al.*, 2006). This composite construct consist of three different but related components: trust, satisfaction, and commitment. These three components are has been used in many empirical studies of relationship quality as a definitive component of relationship quality (Vieira *et al.*, 2008; Hsieh & Li 2008; Roberts *et al.*, 2003; Walter *et al.*, 2003; Ivens, 2004; Ulaga dan Eggert, 2006; Ivens dan Pardo, 2007; Kempeners, 1995; Crosby *et al.*, 1990).

2.3 Customer Trust

Customer Trust is the most important antecedent of customer loyalty. Gummerus *et al.* (2004) found that the lack of trust is the most significant reason for customer for not to adopt the service that involve the financial exchange. Researchers have proven that the customers of on line business generally live far from the vendor that they don’t trust (Reichheld dan Schefter, 2000). They suggested that lack of trust could be a long term obstacles to do business on electronic equipment’s (Roy *et al.*, 2001). However, some approaches have been proposed to quicken the process of customers trust building. Literatures proven that trust is much more difficult to build in on line business environment (Hoffman, 1999). There are some different approaches to explain the concept of costumer trust.

Trust is always be a key element that influence consumer behaviors and it has been proven in an uncertain environment such as internet based trading (Jarvenpaa and Tractinsky, 1999; Jarvenpaa *et al.*, 1999). Palmer *et al.* (2000) argued that building consumer trust in retailer web is very important for the development of B2C E-commerce. Jarvenpaa dan Tractinsky (1999) empirically revealed that trust has a significant direct effect on consumer

buying intention in some cultures. Keen (1999) suggested that trust is a foundation of electronic consumer that focused on the strategic implication of the trust in consumer – marketer relation.

2.4 Customer Loyalty

Walsh *et al.* (2008) defines loyalty as a commitment held firmly to re-buy or reuse the preferred product or service consistently in the future that cause of re-buying the same product or service although there is a situational influence and marketing efforts from competitors that may cause switching behaviors. Baumann *et al.* (2011) argued that loyalty is an attitude and behavior. Ladhari *et al.* (2011) conceptualized loyalty as customer patron of a company. Asserting the role of satisfaction, Guillen *et al.* (2008) noted that empirical studies have indicated the role of customer loyalty in lower insurance sector. According to Lombardi (2005), retaining customers are very important for a company as there is a long term association between the cross-selling and positive recommend intentions. Diacon dan O'Brien (2002) argued that high level retention has a positive correlation with a better financial performance.

Morgan dan Hunt (1994) have developed a theory of loyalty. In their framework, loyalty is viewed as a form of commitment shaped of loyalty as key factor. Trust is defined as an intangible object that could be transferred from trustor to trustee. When trust emerges and transferred, the change of mental attitude form trustor may lead him/her to give an option to trustee to do something that interesting him/her. When giving that option, trustor realized that his/her action involved risk and make it vulnerable to the trustee. Trust can reduce risk or vulnerability that enable the transaction between two parties happen.

2.5 Research Accomplished

Research that has been conducted by Lin and Lu (2010) found that the image of the company has a positive significant effect on trust, and the image of the commodity had the most significant influence on trust, followed by the image of the functional and image of the institution. Structure relational marketing and finance relational marketing positive significant effect on trust, Structure relational marketing has a greater influence on trust than the finance relational marketing, the trust has a positive and significant impact on consumer purchase intentions and positive word of mouth has the effect of moderator between the effect of trust on consumer purchase intentions.

Ishaqa (2012) in his research proved that the company image has no influence in promoting customer loyalty in the telecom industry of pakistan, while the quality of service that is more important by customers. This study helps telecommunications companies to develop customer oriented strategy, also provides insight into the relative importance of the existence of corporate image, perceived value and service quality to build customer loyalty.

Sarwar *et al.*, (2012) in a study analyzing the effect of customer trust on customer loyalty, customer retention and cause related marketing as moderating on the mobile service operators like Mobilink, Telenor, Warid, Ufone and Zong. research results refer that customer trust, customer loyalty and cause related marketing has a positive relationship. yet surprisingly customer trust and customer retention has a negative relationship in the context of Pakistan.

Mosavi and Ghaedi (2012) examined the effects of customer satisfaction, complaint handling and sharing value on trust and test the effects on customer trust, loyalty and commitment intention to repurchase. The result confirmed that the trust is most affected by customer satisfaction (47%), the handling of complaints (30%) and values (22%). In addition, the findings suggest that the impact of the most trust are in customer loyalty (51%), commitment (38%) and the intention to repurchase (29%).

3. RESEARCH METHODS

3.1. Hypotesis & Model

The research is explanatory research. In essence, this study tested the loyalty of the theory of Morgan & Hunt, who said that loyalty is a commitment which is formed by the trust as a major factor. Similar with this, Ribbink *et al.* (2004) also says that when customers have confidence in the services and products of the company, it leads toward loyalty.

The research hypotheses will be tested using the techniques SEM analysis as one of the variables is an intervening variable and too interconnected, and 5 (five) hypotheses that are prepared in accordance with translation of the background issues and literature review and previous research, therefore, described the model in the study. The conceptual framework that will be used in this study, described as follows:

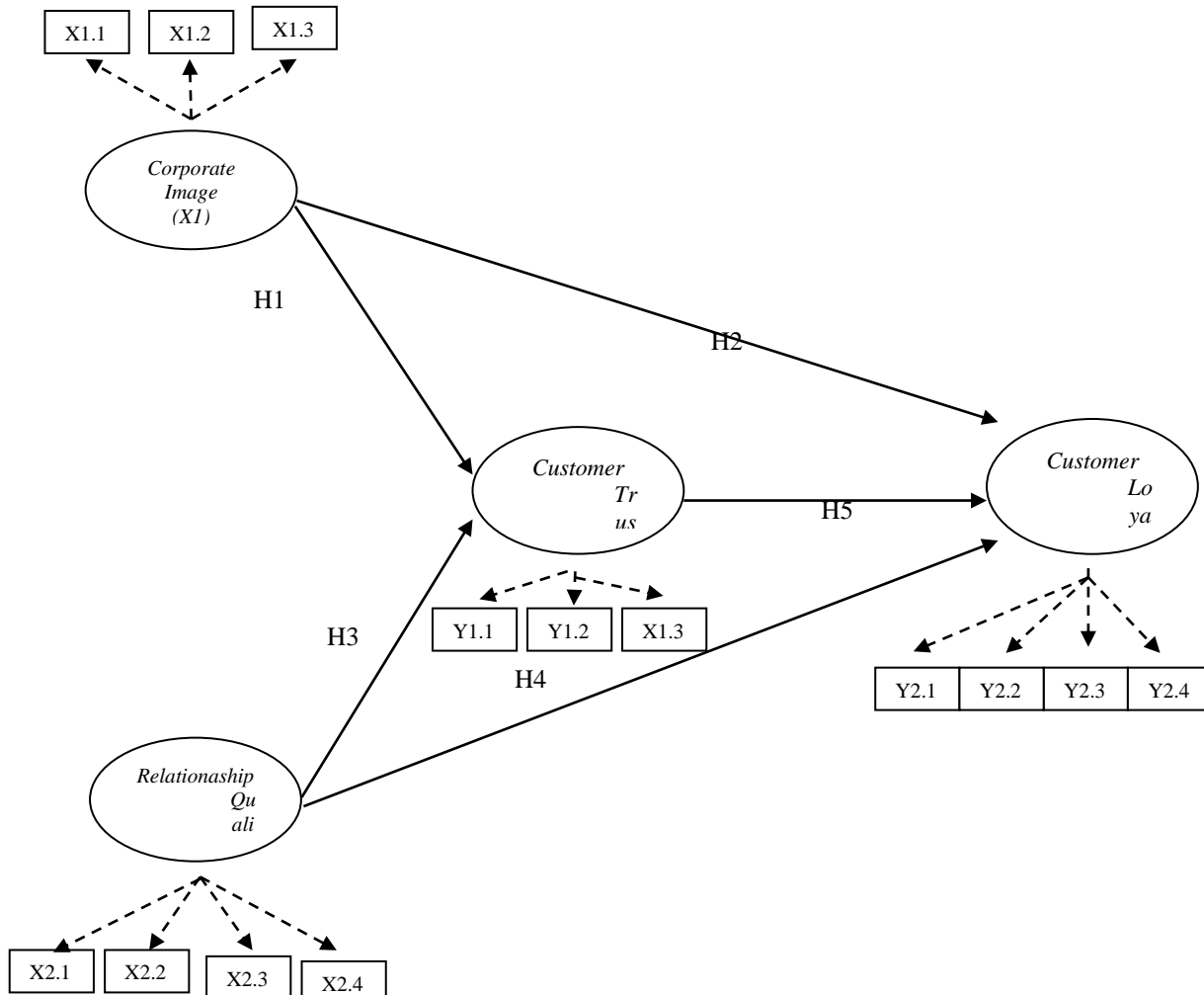

Figure 1. Research Model

Hypothesis as follows:

- H1 = Corporate Image Customer Trust a significant effect on the PT. Garuda Indonesia in Surabaya
- H2 = Corporate Image Customer Loyalty significant effect on the PT. Garuda Indonesia in Surabaya
- H3 = Relationship Quality significant effect on Customer Trust in PT. Garuda Indonesia in Surabaya
- H4 = Relationship Quality significant effect on customer loyalty in the PT. Garuda Indonesia in Surabaya
- H5 = Customer Trust Customer Loyalty significant effect on the PT Garuda Indonesia in Surabaya

3.2 Population and Sampling Method

The population in this study were all passengers PT Garuda Indonesia in Surabaya on various routes a domestic flight from Surabaya, especially the passengers who have the characteristics of the sample:

1. Aged over 18 years
2. At least 3 times using the services of low PT Garuda Indonesia.

- Buying flight tickets PT Garuda Indonesia because of the desire and the decision itself in Office / outlets PT Garuda Indonesia (do not use third-party funds).

This study used a sample of $n = 150$. The sampling technique used in this research is purposive sampling, where each sample is taken by means approached without confirmation or registered in advance, so that every member of the population does not have equal opportunity to be selected into the sample. The questionnaire will be distributed to passengers PT. Garuda Indonesia at Juanda Airport in Surabaya.

This study using an instrument developed from the indicators to get the data sorted into a list of questions:

Table 1 Classification Variable and Indicators

Variable	Indicators	Source
Corporate Image (X ₁)	1. Institution Image (X _{1.1}) 2. Functional Image (X _{1.2}) 3. Comodity Image (X _{1.3})	Walter (1978)
Relationship Quality (X ₂)	1. Frequency (X _{2.1}) 2. Adequacy of time (X _{2.2}) 3. Hospitality (X _{2.3}) 4. Constructive (X _{2.4})	Lin (2005)
Customer Trust (Y ₁)	1. Credibility (Y _{1.1}) 2. Benevolence (Y _{1.2}) 3. Integrity (Y _{1.3})	Mayer <i>et al.</i> , (1995), Mc Knight <i>et al.</i> , (2002)
Customer Loyalty (Y ₂)	1. Continue (Y _{2.1}) 2. Change (Y _{2.2}) 3. Recommended (Y _{2.3}) 4. Defend (Y _{2.4})	- Juga <i>et al.</i> , (2011), - Sharma and Patterson (1999), - Palaima and Auruskeviciene (2007)

Source: Data processed

4. FINDINGS

Having tested the validity and reliability on all latent variables results are valid and reliable, the data is multivariate normal, did not happen singularity and no outliers, then the latent variables can be continued in the form of path analysis diagram is presented as follows:

STRUCTURAL EQUATION MODELING COSTUMER LOYALTY

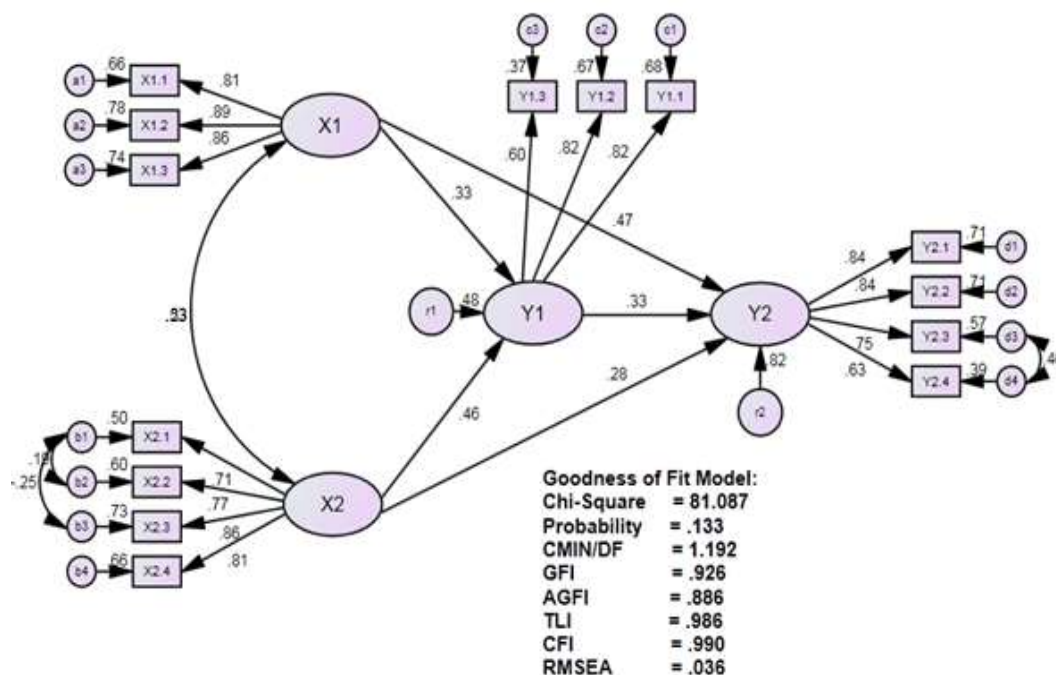

Figure 2. Effect of Corporate image, Relationship quality on Customer loyalty through Customer trust.

Table 2 Goodness of-Fit Index

Criteria	Value Cut – Off	Results	Description
Chi Square	Expected tiny	81.087	x2 with df = 164, is 194 883 Good
Significance Probability	≥ 0,05	0,133	Good
RMSEA	≤ 0,08	0,036	Good
GFI	≥ 0,90	0,926	Good
AGFI	≥ 0,90	0,886	Passably/Pretty Good
CMIN/DF	≤ 2,00	1,192	Good
TLI	≥ 0,90	0,986	Good
CFI	≥ 0,90	0,990	Good

Source: Data processed

Table 2, shows the entire value of goodness of fit properly in accordance with the cut of value, except the index below 0.886 AGFI is cut of value. Thus it can be said that the empirical data used are in accordance with the conceptual framework.

The following are the test results match the structural model derived from the output syntax on the structural equations. The evaluation of the structural models related to testing the causal relationship between the latent variables in this study have the structural equations generated as follows:

$$Y_1 = 0,329 X_1 + 0,462 X_2$$

$$Y_2 = 0,466 X_1 + 0,275 X_2 + 0,325 Y_1$$

Description :

- X₁ = Corporate image (X₁)
- X₂ = Relationship quality (X₂)
- Y₁ = Customer trust (Y₁)
- Y₂ = Customer loyalty (Y₂)

Normality of the data is a prerequisite for modeling SEM. Testing normality emphasis on multivariate data by looking at the value of skewness, kurtosis, and statistics can be seen from the Critical Ratio (CR). If used a significance level of 5 percent, then the value CR which is between -1.96 until 1.96 (-1.96 ≤ CR ≤ 1.96) is said to be normal distribution of data, both univaariat and multivariate analyzes.

The singularity can be seen through the determinant of the covariance matrix. Value determinants of very small or close to zero indication of the presence of singularity problem, so it can not be used for research. The results of the research value of the sample covariance matrix Determinant of 0019. This value is almost medekati of zeros so that it can be said that there is no singularity problem on the analyzed data.

Multikolinearitas occur if there is a latent variable exogenous of more than one and there is a correlation. The value of the correlation between the latent variables Corporate image (X₁) with Relationship quality (X₂) is 0.230 with p = 0094 is greater than the significance level α = 0.05, it can be said does not happen multikolinearitas.

Outlier test results in this study are presented in the Mahalanobis distance or Mahalanobis d-squared. Mahalanobis value greater than Chi-square table or value p₁ <0.001 say outlier observations. In this study, there are two data outliers, because they are smaller than 5 data, it can be said does not happen outlier.

Table 3 Path Coefficient Model Test Results

Variable	Coefficient	C.R.	Prob.	Result
Corporate image (X ₁) → Customer trust (Y ₁)	0,329	3,229	0,001	Significant
Relationship quality (X ₂) → Customer trust (Y ₁)	0,462	4,183	0,000	Significant
Corporate image (X ₁) → Customer loyalty (Y ₂)	0,466	5,876	0,000	Significant
Relationship quality (X ₂) → Customer loyalty (Y ₂)	0,275	3,322	0,000	Significant
Customer trust (Y ₁) → Customer loyalty (Y ₂)	0,325	3,384	0,000	Significant

Source: Data processed

Table 3, shows the path coefficient is Corporate image (X1) positive and significant impact on the Customer trust (Y1), which means that every increase in Corporate image (X1) will increase customer trust (Y1). Relationship quality (X2) positive and significant impact on the Customer trust (Y1), which means that every increase in relationship quality (X2) will increase customer trust (Y1). Corporate image (X1) positive and significant impact on customer loyalty (Y2), which means that every increase in corporate image (X1) will raise Customer loyalty (Y2). Relationship quality (X2) positive and significant impact on customer loyalty (Y2), which means that every increase in relationship quality (X2) will raise Customer loyalty (Y2). Customer trust (Y1) positive and significant impact on customer loyalty (Y2), which means that every increase in customer trust (Y1) will increase customer loyalty (Y2).

5. DISCUSSION

5.1 Corporate Image Significant Impact On Customer Trust

The results of this study prove PT Garuda Indonesia is an airline that has a corporate image: (1) nice and dedicated and have the capability in the field of business, (2) has a office building marketing and outlet with the interior design is magnificent and comfortable as well as attributes of luxury, (3) provide good services when customers are still there on the ground and when the passenger in flight, (4) provide conformity price of the product or service with quality products and services provided, (5) submit the form and program promotion activities were good and quality, (6) have products aviation services nice, (7) is one of the airlines in Indonesia, which has a good reputation, and (8) have several brand products in good standing aviation services, an example of 'Citilink & Aerowisata'. The corporate image significantly affect the confidence of respondents to the PT Garuda Indonesia where PT. Garuda Indonesia is believed to: (1) owns and operates a fleet of the latest aircraft types to serve passengers, (2) have quality certificates and charter associated with the products and services offered to passengers, (3) renew programs that are offered to passengers according to market needs, (4) provide services that best fit the needs of passengers, (5) provide solutions when passengers have problems while enjoying the services of flight, (6) PT Garuda Indonesia fulfill the promise of sale delivered on passengers, (7) the staff of PT Garuda Indonesia offers and provide optimal services and assistance to passengers whether requested or not as promised provide the best services, and (8) PT Garuda Indonesia responded quickly to all complaints submitted by passengers and handle it completely.

Baines et al. (2004: 358) says that a good corporate image ultimately create public trust in the company. Based on the statistical test results of this study support the concept by proving that the corporate image PT Garuda Indonesia positive and significant impact on customer trust. This means that if response Corporate image PT Garuda Indonesia is positive then the response to the Customer trust PT Garuda Indonesia will also be higher. The results of this study are also consistent with the results of research Christodoulides & Charnatony (2009) who found that brand image has an impact on the consumer decision to

buy, so a good brand with a positive image allows to be trusted by consumers (Customer Trust). The same thing was found also by Mickiewicz et al. (2011) in which Mickiewicz studied the company's image in the business sector and found that the image of the company has a significant positive influence to achieve customer confidence. In some ways the image of the company is a valuable asset and that the company needs to manage (Abratt & Mofokeng, 2001).

5.2 Corporate Image Significant Impact on Customer Loyalty

The results of this study also proves corporate image PT Garuda Indonesia as an airline that has significantly affect the loyalty of respondents to the PT Garuda Indonesia, where respondents: (1) will repeat using the products and services PT Garuda Indonesia, (2) will use the product or other programs that are owned by PT Garuda Indonesia, (3) will follow the subscription program offered by PT Garuda Indonesia, (4) will not use the company's products other than flight service products PT Garuda Indonesia, (5) will invite relatives, friends and associates using flight service products PT Garuda Indonesia, (6) will help PT Garuda Indonesia to promote programs to public companies, (7) will give positive testimonials about the company in the media or in every opportunity, and (8) will always talk about the positive things about PT Garuda Indonesia to society encountered.

Hypothesis 2 (two) are accepted, but the results of this study do not support previous research that has been done by Ishaqa (2011) in his study showed that the company image has no influence in promoting customer loyalty in the telecommunications industry in Pakistan. Differences in the results of this study, it was possible considering the object of research that discussed also different, Ishaqa (2011) examined the telecommunications industry that puts service and network coverage excellence and wide to attract consumers being, this research focused on the aviation industry which is associated with the lives of passengers where the safety of passengers and timeliness to be a major destination for customers in deciding choice of airline.

Service industries such as airlines have been forced to identify new ways not just simply a way to give low prices to create and sustain competitive advantage. In the present state of increasing global competition, there is a sustained increase in the need to meet customer expectations (Jan, Abdullah, and Smail, 2013) where the expectation is very important is the capability and the ability of the airline as an operator of air transportation that is reliable and has a good reputation provides aviation services convenient and secure.

5.3 Relationship Quality Significant Impact on Customer Trust

The results of this study indicate relationship quality (X2) positive and significant impact on the customer trust (Y1), so that these results support Garbarino and Johnson (1999), which revealed that the relationship marketing can effectively improve customer perception on trust (Customer Trust) and commitment. This is evident from the marked positive path coefficient of 0,462 with a value of C.R. amounted to 4.183 and acquired a significance probability (p) of 0.000 which is smaller than the significance level (α) which is set at 0.05. Thus Relationship quality (X2) directly affect customer trust (Y1) amounted to 0,462, which means that every increase in Relationship quality (X2) will increase customer trust (Y1)

Upon the acceptance of the hypothesis to 3 (three) in this study, mean results of this study support the ideas that show that construct global on relationship quality, as reflected by a combination of commitment, trust, and satisfaction, so that could offer the best judgment on a strength of the relationship and providing insight into the changes in performance (Wulf et al., 2001), in other words the statistical test results prove that the relationship quality built PT Garuda Indonesia and significant positive effect on customer trust in PT Garuda Indonesia.

In the end it can be concluded that the increase in the number of passengers PT Garuda Indonesia since 2008, one of them be to the success of the strategy relationship Quality which in turn will create a Customer Trust and is also considered capable of influencing the customer loyalty. Success of PT Garuda Indonesia in accordance with the disclosed Evans and Laskin (Wibowo, 2006) Relationship Quality that will help companies build long-term

alliances with customers and prospective customers, work together to achieve one goal which is determined based on the principle of trust.

5.4. Relationship Quality Significant Impact on Customer Loyalty

Based on the statistical test results prove that the relationship quality and significant positive effect on customer loyalty. Thus, it means if the relationship quality PT. Garuda Indonesia more qualified then Customer loyalty respondents to PT. Garuda Indonesia will also be higher. In this research it is clear that the model Relationship Quality PT Garuda Indonesia are more focused on long-term customer relationships rather than on short-term transactions, this study provide empirical evidence on the statement Szulanski (1996) and Lin (2005) that informality, openness and density of communication closely related to the quality of relationships (relationship quality) because PT Garuda Indonesia has : (1) indicate a higher level of engagement and frequency of interaction between the sender and receiver, (2) increase the openness of communication, exchange spontaneous and open information and ideas between the parties that interact and (3) creating the potential for a variety of individual exchanges.

Directly basically the results of this study support the theory that shows that high-quality relationships that can get customers for life and a commitment is invaluable to a business. This study also provides empirical evidence about: A good relationship with the customers is the result of a competitive advantage long-term business, and success depends on its ability to build positive relationships with customers (Claycomb & Martin, 2000: 385 & 396). In order to build and maintain sales relationships with customers, PT Garuda Indonesia have built a relationship of good quality.

5.5 Customer Trust Significant Impact on Customer Loyalty

Hypothesis five (5) it's proven, means that if the customer trusts PT Garuda Indonesia the higher, the response Customer loyalty PT Garuda Indonesia will also be higher. The results also support and encourage research that has been done before by Mosavi and Ghaedi (2012) where the results of these studies are positive and significant effect of trust on customer loyalty, commitment, buy-back.

Based on the results of statistical tests in this study that proves that customer trust and significant positive effect on customer loyalty, unfortunately the present study does not support previous research that has been done by Sarwar et al. (2012) in Pakistan which results in a Customer Trust and Customer Retention has a negative relationship.

6. CONCLUSION AND RECOMMENDATION

6.1 Conclusion

1. This research is the study of the theory of marketing management in terms of confirming the fundamental analysis of the influence of corporate image (external information) to customer loyalty either directly or through customer trust, and also confirmation of the fundamental analysis of the influence of relationship quality (internal information) to customer loyalty either directly or through customer trust, and the latter confirmed the fundamental analysis of the influence of the trust customer directly to customer loyalty. the results of this study indicate that the corporate image and relationship quality has direct impact on customer loyalty or through customer trust, and customer trust does have a significant direct effect on customer loyalty.
2. As the national airline biggest, and shares owned by the government of Indonesia, PT Garuda Indonesia able to position ourselves as the airline with passenger growth rate of over 20% per year. PT Garuda Indonesia success was due to the foresight of PT Garuda Indonesia in implementing the strategy External Information through corporate image, especially in the functional image which includes imaging through the promotion of an elegant, suitability prices between the products and services provided to customers, image of excellent service to its customers, In this study has demonstrated that corporate image which is run by PT Garuda Indonesia became the most important variables in the marketing strategy to increase customer loyalty PT Garuda Indonesia.

3. The path coefficient from customer trust provides the largest indirect effect on relationship quality (Internal Information) on customer loyalty. Relationships built by PT Garuda Indonesia to subscribers through constructive of communication and the hospitality of the cabin crew and the crew ashore to make customers feel no bond and appreciated, it is this which raises the Customer Trust on the performance of PT Garuda Indonesia as a whole, so that the relationship quality that underlies the trust will be able to increase customer loyalty PT Garuda Indonesia.

6.2 Suggestion

6.2.1 Feedback for Management:

1. The company must more attention External Information through Institution Image, functional image and commodity image, Which includes: the image of the airline; offices and service outlets; services image; price image; and promotion image. Companies are advised to make the project a strong and positive reputation for their stakeholders, namely employees, customers, investors and communities. The Company provides specialized services to consumers and society. The company uses good corporate communication strategy in building a positive perspective of customers on the corporate image. Thus, the corporate image is the result of the communication process when companies create and disseminate specific message in the form of a vision, mission, goals, strategy and identity that reflects the core values of the company.
2. The company must more attention to internal information through good communication with focusing on frequency, adequacy of time, hospitality, and the level of constructive, to be implemented on relationship quality strategies. Companies build relationship with customer and suppliers to get valuable information on how best to serve customers and suppliers as well as keep them did not flee to a competitor. It is considering that the quality of the relationship between the parties involved is important as a determinant of loyalty. The best way to retain customers is to satisfy customer needs and build trust and customer loyalty. Therefore, in order to build and maintain sales relationships with customers, employers should establish good relationship quality.
3. The company must more attention on elements: credibility, benevolence, and integrity, because this elements is crucial for successfully achieving in long-term relationship is the establishment and maintenance of trust. Airline companies is still in its infancy can be adapting this strategies, the trust is very important in the world of aviation and air transport services, the rise in consumer trust helped customers to deliver customer value for improve performance of company. The trust has always been an important element in influencing consumer behavior and has proved significant in an uncertain environment. The trust has a direct influence significant repeat purchase intentions of consumers, which is one form of customer loyalty.
4. Companies must more attention to continue, change, recommended, and defend. Companies must attention to situational factors, individual factors, resistance to change and socio-cultural factors, also social ties, all this factor can form a reason to distinguish loyal behavior from loyal attitude.

6.2.2 Suggestions for Further Research;

1. Testing the variables other of External and Internal Information, which is related and influence on customer trust and customer loyalty in the airline industry. Such as variable service quality, product quality, and customer satisfaction, situational factors, and personal factors.
2. More extending the reach populations not only in Surabaya, but also in Indonesia, so the study will explain the relationship of variables in a wider scale.
3. In addition to the airline industry, this research should be tested for other transportation industries or service industries that have direct contact with service users, so that later known how the role of corporate Image and Relationship Quality influence either directly or through customer trust on customer loyalty, have whether or no such a significant role in the study

REFERENCES

- Abratt, R. & Mofokeng, T.N. (2001). "Development and management of corporate image in South Africa". *European Journal of Marketing* Vol.35, No. 3/4 pp. 368-386.
- Adkins, S., (2004), *Cause related marketing: who cares wins*. Oxford: Elsevier Butterworth-Heinemann
- Baumann, et al., (2011). Modelling customer loyalty in financial services: A hybrid of formative and reflective constructs. *International Journal of Bank Marketing*, 29(3), 247-267. <http://dx.doi.org/10.1108/02652321111117511>
- Bravo, et al., (2009). The role of bank image for customers versus non-customers, *Internatinal Journal of Bank Marketing*, 27(4), 315-334
- Chattananon, et al., (2008). Impacts of a Thai cause-related marketing program on corporate image. *Int. J. Emerg. Mark.* 3(4): 348-363.
- Chung, B. G., & Schneider, B. (2002). Serving multiple masters: role conflict experienced by service employees. *Journal of Services Marketing*, 16(1), 70-87.
- Christodoulides, G. and Leslie de Chernatony, (2009). Consumer-based brand equity conceptualization and measurement. *International Journal of Marketing*, 52: 43-65
- Claycomb, C. and Martin, C. L. (2002) Building Customers Relationships: An Inventory of Service Providers' Objectives and Practices, *The Journal of Services Marketing*, 16(7), pp.615-635
- Crosby, L.A., Evans, K.R. and Cowles, D. (1990), Relationship quality in services selling: an interpersonal influence perspective, *Journal of Marketing*, Vol. 54, pp. 68-81.
- Diacon, S., & O'Brien, C. (2002). *Persistency in UK long-term insurance: customer satisfaction and service quality*. CRIS Discussion Papers, III. Nottingham: University of Nottingham.
- Ellinger, A. E., Daugherty, P. J., & Plair, Q. J. (1999). Customer satisfaction and loyalty in supply chain: the role of communication. *Transportation Research*, 35, 121-134.
- Evans, J. R., & Laskin, R. L. (1994). The relationship marketing process: Conceptualization and application., *Industrial Marketing Management*, 23(5).
- Garbarino, E. and Johnson, M.S. (1999), "The different roles of satisfaction, trust, and commitment in customer relationships", *Journal of Marketing*, Vol. 63 2, April, pp. 70-87.
- Gummerus, J., V. Liljander, et al. (2004). "Customer loyalty to content-based Web sites: the case of an online health-care service." *Journal of Services Marketing* 18(3): 175-186.
- Hatch, M.J., Schultz, M. and Williamson, J. (2003), "Bringing the corporation into corporate branding", *European Journal of Marketing*, Vol. 37 No. 7/8, pp. 1041-64.
- Hennig-Thurau, T., Gwinner, K. P., & Gremler, D. D. (2002). Understanding relationship marketing outcomes: an integration of relational benefits and relationship quality. *Journal of Service Research*, 4(3), 230.
- Hsieh, H. Y., Li, S. H., "A Relative Influence of Service Quality and Relationship Quality on Customers' Loyalty for Restaurants". *Department of Food and Beverage Management, Far East University*. 2008.
- Ishaqa, M. I. (2012). Perceived Value, Service Quality, Corporate Image and Customer Loyalty: Empirical Assessment from Pakistan. *Serbian Journal of Management*, 7(1), 25-36. <http://dx.doi.org/10.5937/sjm1201025I>
- Ivens, B. S. and Pardo, C. (2007), "Are key account relationships different? Empirical results on supplier strategies and customer reactions", *Industrial Marketing Management*, Vol. 36, No.4.
- Jan, M. T., Abdullah, K., & Smail, M. H. (2013). Antecedents of loyalty in the airline industry of Malaysia: An examination of higher-order measurement model. *Proceedings of 3rd Asia-Pacific Business Research Conference*, Kuala Lumpur, Malaysia, 1-14.
- Jarvenpaa, S. L., and N. Tractinsky, (2005) "Consumer trust in an Internet store: A cross-cultural validation", *Journ al of Electronic Commerce Research*, Vol. 6, No.3.
- Jarvenpaa, S. L., N. Tractinsky and M. Vitale, , (1999), "Consumer trust in an Internet store", *Information Technology and Management*, Vol. 1, No. 12:45-71
- Juga J, Juntunen J., Juntunen M ,(2011)., "Impact of service quality, image and relational aspects on satisfaction and loyalty in logistics outsourcing relationships" (www oulu.fi/)

- Kazoleas D, Kim Y, Moffitt MA (2001). *Institutional image: A Case Study. Corporate Communications*, 6(4): 205-216.
- Kandampully, J., and Hu, H.H., (2007), "Do hoteliers need to manage image to retain loyal customers?", *International Journal of Contemporary Hospitality Management*, Vol. 19, No. 6, pp. 435 – 443.
- Kim, K. H., Jeon, B. J., Jung, H.S., Lu, W., & Jones, J. (2011). Effective employment brand equity through sustainable competitive advantage, marketing strategy, and corporate image. *Journal of Business Research*, 64, 1207-1211.
- Keen, P.G.W., (1999). *Electronic Commerce Relationships: Trust by Design*, Englewood Cliffs, NJ: Prentice-Hall,.
- Ladhari, R., Ladhari, I., & Morales, M., (2011), Bank service quality: comparing Canadian and Tunisian customer perceptions. *International Journal of Bank Marketing*, 29(3).
- Lin, Long-Yi and Ching-Yuh Lu ,(2010), The influence of corporate image, relationship marketing, and trust on purchase intention: the moderating effects of word-of-mouth, *Q Emerald Group Publishing Limited*, ISSN 1660-5373, VOL. 65 NO. 3 2010, pp. 16-34.
- Lin, X. (2005). Local Partner Acquisition of Managerial Knowledge in International Joint Ventures: Focusing on Foreign Management Control. *Management International Review*, 45(2), p. 219-237.
- Lombardi, L.J. (2005). The importance of client retention. *LIMR A's MarketFacts Quarterly*, 24(2),
- Mayer, R. C., Davis, J. H., and Schoorman, F. D. (1995). An integrative model of organizational trust, *Academy of Management Review*, 20, 3, 709-734.
- Mickiewicz, J et al. (2011). Corporate image in the leisure services sector. *Journal of Services Marketing*.
- McKnight, D. H., Choudhury, H., Kacmar, C. (2002). The impact of initial consumer trust on intentions to transact with a web site: A trust building model. *Journal of Strategic Information Systems*, 11, 297-323.
- Mosavi, S.A. and Ghaedi, M. (2012). A survey on the relationships between customer satisfaction, image, trust and customer advocacy behavior. *African Journal of Business Management* Vol. 6(8), pp. 2897-2910
- Morgan, R. M., and Hunt, S. D., (1994), The commitment-trust theory of relationship marketing. *Journal of Marketing*, 58(3), 20-38.
- McKnight, D. H. and N. L. Chervany, (2002) "What trust means in e-commerce customer relationships: An interdisciplinary conceptual typology", *International Journal of Electronic Commerce*, Vol. 6, No. 2: 35-60.
- Miyamoto, T., & Rexha, N. (2004). Determinants of three facets of customer trust A marketing model of Japanese buyer-supplier relationship. *Journal of Business Research*, 57, 312-319.
- Nguyen, N. (2006), "The collective impact of service workers and servicescape on the corporate image formation", *International Journal of Hospitality Management*, Vol. 25 ,No. 2, pp. 227-44.
- Nguyen, N., & Leblanc, G. (2001), "Corporate image and corporate reputation in consumers' retention decisions in services", *Journal of Retailing and Consumer Services*, 8: 227-236.
- Pappas, J. M., & Flaherty, K. E. (2008).The effect of trust on customer contact personnel strategic behavior and sales performance in a service environment. *Journal of Business Research*, 61, 894-902.
- Palaima, T. & Auruskeviciene, V. (2007). Modeling relationship quality in the parcel delivery services market. *Baltic Journal of Management*, 2(1), 37-54.
- Palmer, J.W., J.P. Bailey, and S. Faraj,(2000), "The role of intermediaries in the development of trust on the WWW: The use and prominence of trusted third parties and privacy statements", *Journal of Computer Mediated Communications*, Vol. 5, No. 3.
- Palmatier, Robert W., Rajiv P. Dant, Dhruv Grewal, and Kenneth R. Evans (2006), "Factors Influencing the Effectiveness of Relationship Marketing: A Meta-Analysis." *Journal of Marketing* 70 (October), 136-53.

- Pappas, J. M., & Flaherty, K. E., (2008), The effect of trust on customer contact personnel strategic behavior and sales performance in a service environment. *Journal of Business Research*, 61, 894–902.
- Reichheld, F. F. and P. Scheffer (2000). "E-Loyalty: Your Secret Weapon on the Web." *Harvard Business Review* 78(4): 105-113.
- Ribbink, D., Liljander, A. C. R. V. V., & Streukens, S. (2004). Comfort your online customer: quality, trust and loyalty on the internet. *Managing Service Quality*, 14(6), 446-456.
- Ruyter, K. D., Moorman, L., & Lemmink, J.(2001).Antecedents of Commitment and Trust in Customer–Supplier Relationships in High Technology Markets. *Industrial Marketing Management*, 30, 271–286.
- Roberts, K., Varki, S. and Brodie, R. (2003), “Measuring the Quality of Relationships in Consumer Services: An Empirical Study”, *European Journal of Marketing*, Vol. 37, No. ½.
- Robertson, T.S. and Gatignon, H. (1986), Competitive effects on technology diffusion, *Journal of Marketing*, Vol. 50 No. 3, pp. 1-12.
- Roy, M., O. Dewit, *et al.* (2001) The impact of interface usability on trust in web retailers. *Internet Research: Electronic Networking Applications and Policy* 11(5): 388-398.
- Sarwar M, Abbasi K and Pervaiz S (2012). The Effect of Customer Trust on Customer Loyalty and Customer Retention: A Moderating Role of Cause Related Marketing. *Global Journal of Management and Business Research* 12(6) 2249-4588.
- Sharma, N., Patterson, P.G., 1999. The impact of communication effectiveness and service quality on relationship commitment in consumer, professional services. *The Journal of Services Marketing*, 13(2), 151-170.
- Swan, J.E., Bowers, M.R. and Richardson, L.D. (1999), “Customer trust in the salesperson: an integrative review and meta-analysis of the empirical literature”, *Journal of Business Research*, Vol. 44, pp. 93-107.
- Slatten, Terje., (2008), “Antecedents & Effects Of Emotional Satisfaction On Employee-Perceived Service Quality”, *Journal of Managing Service Quality*, pp. 370-386.
- Szulanski, G. (1996): “Exploring Internal Stickiness: Impediments to the Transfer of Best Practice within the Firm”, *Strategic Management Journal*, Vol. 17 (Special Issue).
- Walsh, G., Evanschitzky, H., & Wunderlich, M. (2008). Identification and analysis of moderator variables: Investigating the customer satisfaction-loyalty link. *European Journal of Marketing*, 42(9), 977-1004.
<http://dx.doi.org/10.1108/03090560810891109>
- Walters, C.G. and Paul, G.W. (1970), *Consumer Behavior: An Intergated Frame Work*, New York, NY, Richard D. Irwin.
- Walters, C.G. (1978), *Consumer Behavior: An Integrated Framework*, New York, NY, Richard D. Irwin.
- Walter, A., Muller, T., Helfert, G. and Ritter, T. (2003), “Functions of industrial supplier relationships and their impact on relationship quality”, *Industrial Marketing Management*, Vol. 32, No. 1, pp. 159-69.
- Wibowo, S. (2006), “Implementasi Releationship Marketing Pada Industri Hospitality”, *Utilitas*, Vol 14 No 2, Juni.
- Wulf, K., G. Odekerken-Schroder and D. Iacobucci (2001) Investments in Consumer Relationships: A Cross-country and Cross-industry Exploration, *Journal of Marketing*, 65(4), pp.33-50.